

MBRA PALLET FORKS



1 844 842 5141

info@bigfootcrane.com

www.bigfootcrane.com

Save time and money with the MBRA-E Auto Leveling Pallet Forks from Boscaro.

Lift safely and efficiently with these versatile pallet forks. An internal spring system automatically levels your load to the most neutral position, and the adjustable verticle riser and tines ensure that no load is too big or too small to handle.

All Boscaro below-the-hook accessories are certified for use across North America and meet or exceed ASME-TH1/B30.20 standards.

Each unit comes with a dedicated serial number and conformity statement which ensures compliance with ASME.

The best money we've ever spent on crane accessories.

Mike Dawson,
President

Big Red Crane Company, Inc.





MBRA PALLET FORKS



📞 1 844 842 5141

✉ info@bigfootcrane.com

🌐 www.bigfootcrane.com

Features

- ✔ Automatic load leveling
- ✔ Telescopic vertical riser and adjustable sliding forks
- ✔ Lightweight to maximize lift capacity
- ✔ Meets or exceeds all ASME Standards
- ✔ Durable powder coated finish

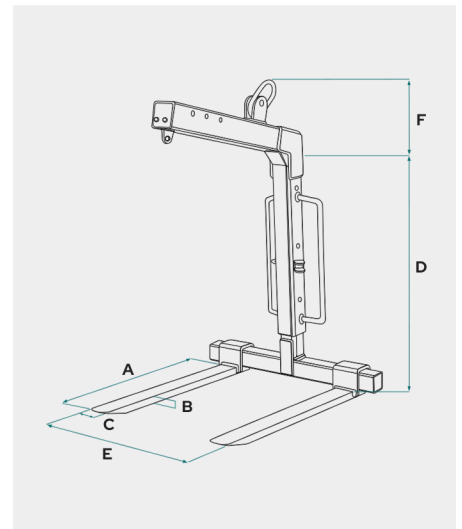

Model	Cap. (lb)	Model						Weight (lb)
		A	B	C	D	E	F	
MBRA-15E	3,307	3'3"	1.38"	3.94"	3'9"-5'7"	1'2"-3'11"	2'2"	342
MBRA-20E	4,409	3'3"	1.38"	4.72"	3'9"-5'7"	1'3"-3'2"	2'2"	375
MBRA-25E	5,512	3'3"	1.57"	3.54"	4'2"-6'0"	1'4"-3'3"	2'2"	485
MBRA-30E	6,614	3'3"	1.97"	4.72"	4'2"-6'0"	1'2"-3'3"	2'2"	562

Products with * are a special order item

