

SAFE EFFICIENT STRONG

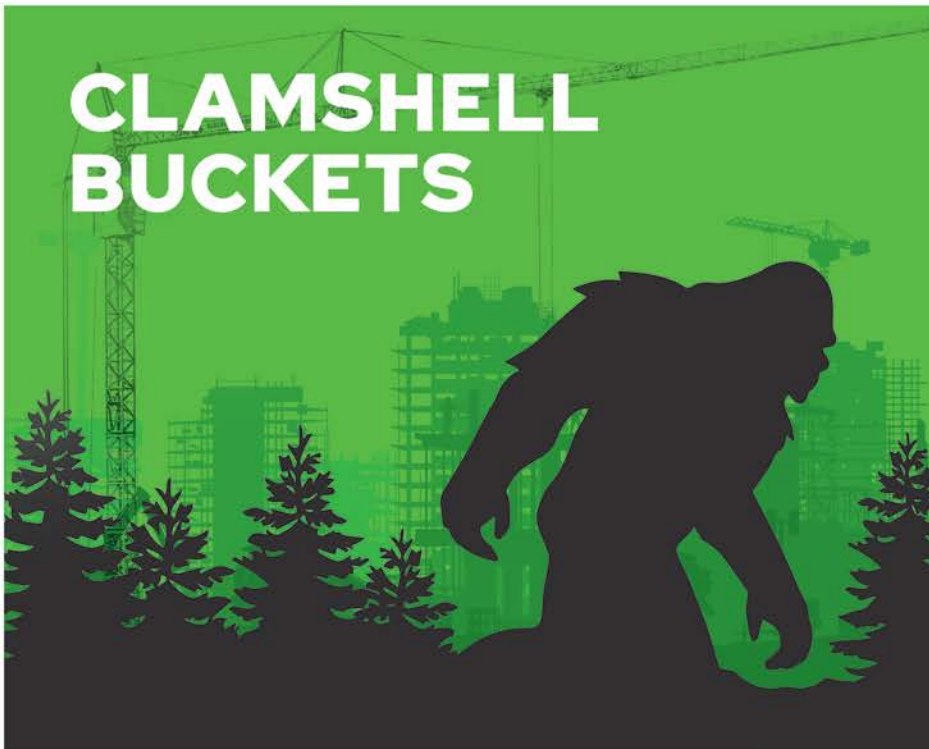

☎ 1 844 842 5141

✉ info@bigfootcrane.com

🌐 www.bigfootcrane.com

Our clamshell buckets bring precise control and enhanced productivity to a range of industries, from construction to waste management. Built for durability and versatility, they excel at moving sand, gravel, soil, and other loose materials.



Features

- ✔ Excellent choice for large landscaping, mining, digging and construction projects
- ✔ Discharges directly from the base by lever
- ✔ Great for landscaping supplies, reducing the need for shoveling
- ✔ Meets or Exceeds all ASME Standards



CLAMSHELL BUCKETS



📞 1 844 842 5141

✉️ info@bigfootcrane.com

🌐 www.bigfootcrane.com

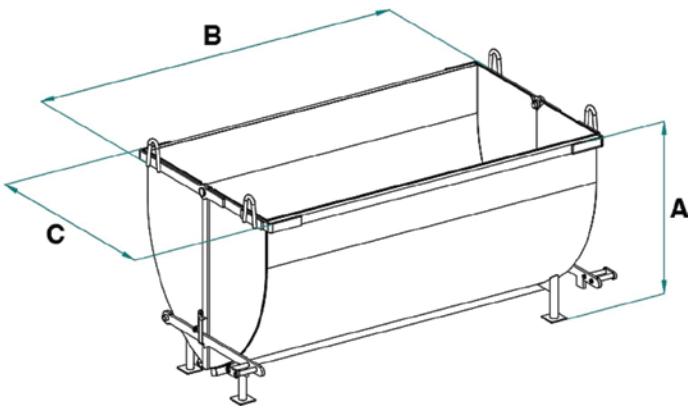

Configuration Chart

Model	Capacity	Dimensions			Capacity (lb)	Weight (lb)
		A	B	C		
A-99S*	1.31 cu yd	3'5"	4'7"	4'0"	4,409 lb	419 lb
A-150S*	1.96 cu yd	3'5"	5'11"	4'0"	6,614 lb	584 lb
A-200S	2.61 cu yd	3'10"	7'3"	4'0"	8,818 lb	892 lb
A-300S*	3.92 cu yd	4'4"	7'3"	5'1"	13,228 lb	1,345 lb

Products with * are a special order item

